

# MRI-Compatible Insert Earphones - Model S14

## Instructions

The S14 insert earphones are designed for use in MRI scanners. They provide both high-quality acoustic stimulation and substantial attenuation of background noise, while causing very little or no disruption of the scanner image.

### I. Setting Up

The three main components of the S14 earphone system are:

- 1) an audio transformer,
- 2) a long (~9 m) cable, and
- 3) a short (~0.5 m) cable with the insert earphones at one end.

The schematic figure below shows these components connected in a typical configuration in which a PC delivers left (blue) and right (red) audio signals. These signals must be amplified by an audio amplifier (not included in the S14 system) before delivery to the transformer. The amplifier must be capable of delivering a few watts.

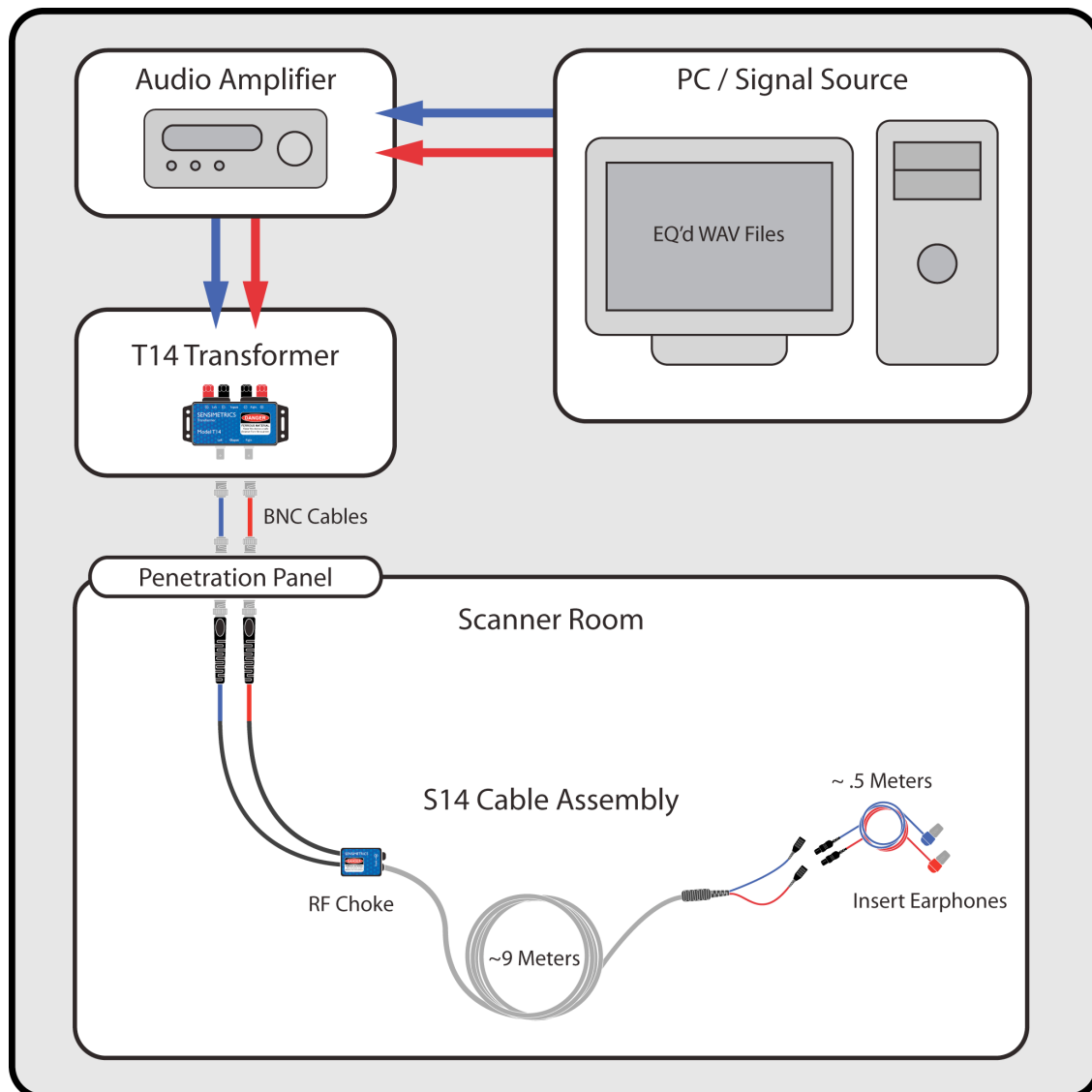

The preferred setup is to keep the transformer outside of the scanner room with connection to the long cable made via a penetration panel or an intermediate cable. The outer conductor of the BNC connectors may be grounded or floating. Be careful to maintain consistent signal polarity between left and right channels.

**NOTE THAT THE BNC CONNECTORS AT THE END OF THE LONG CABLE CONTAIN MAGNETICALLY ATTRACTIVE METAL. THEY SHOULD BE KEPT A SAFE DISTANCE FROM THE SCANNER.**

**THE TRANSFORMER IS ALSO MAGNETICALLY ATTRACTIVE. IF IT IS TAKEN INTO THE SCANNER ROOM IT SHOULD BE KEPT A SAFE DISTANCE FROM THE SCANNER.**

The short cable enables the subject to insert the earphones, and to don an additional hearing-protector muff if desired, prior to entering the scanner room where connection to the long cable can then be made. To insert each earphone, first attach a clean Comply tip to the earphone. Then compress the Comply tip by rolling between thumb and forefinger and insert it into the ear canal. Hold it in the ear for about 10 sec while the foam expands.

## **II. Acoustic Performance**

Acoustic measurements were made with the earphones installed on a KEMAR manikin equipped with Zwislocki couplers. In order to ensure repeatable measurements, KEMAR's pinnae were removed and the earphones with Comply tips were inserted directly into the circular steel ear canals, resulting in a good acoustic seal.

### **A. Frequency Response and Output Level**

Frequency responses of the left and right S14 earphones are shown in the upper panels on the accompanying file (S14\_XXXX\_YYYY.pdf). The black dashed lines show the responses of the transducers to a white noise stimulus. The ordinate values are given in terms of the sound pressure level in the ear canal for a 0 dBV narrowband signal measured at the input to the transformer.

The frequency responses of the transducers typically have a strong resonance around 5 kHz. This response can be flattened by digital filtering. The red and blue lines in the upper plots each show the response to white noise that was pre-filtered with a custom equalization (EQ) filter. The magnitude responses of these filters are shown in the middle panels. These correction filters are supplied on the product CD-ROM and can be used for pre-filtering stimuli by the EQ Filtering utility provided with the S14 system.

### **B. Distortion**

Measurements of harmonic distortion at three signal frequencies are shown in the bottom panels. Max distortion is defined as the level of the largest of the components at integer multiples of the fundamental stimulus frequency.

## **III. Cleaning and Maintenance**

- Use clean Comply tips with each subject. Replacement tips can be ordered from [www.hearingcomponents.com](http://www.hearingcomponents.com)
- Check that there is no ear wax or other debris blocking the adapter tip of the earphone.
- Establish a quick but repeatable check for gross changes in acoustic performance.